

# V-Gard® Accessory System

Face Protection Products for MSA Safety Helmets



The V-Gard Accessory System is a full line of frames, visors and chin protectors that meet many global standards, including ANSI/ISEA Z87.1-2010, CSA Z94.3, EN166 and AS/NZS 1337, as well as many local standards.

Convenient. Compliant. Compatible. That's the V-Gard Accessory System from MSA.



*Because every life has a **purpose...***



### Keys to Safety: Testing as a System to Exceed the Standard

MSA is serious about safety. To help ensure safety, don't combine accessories from different manufacturers. **Only** V-Gard Accessory products are tested and approved as a fully-integrated system to work with MSA protective helmets. Most V-Gard Accessories exceed the impact protection requirements of ANSI/ISEA Z87.1-2010 and CSA Z94.3. V-Gard Accessories have stood up to:

- a 1/4" metal ball speeding > 204 mph.
- a > 1 lb. pointed metal missile and a sharp, added-weight needle being dropped from a height > 4 feet.

V-Gard Accessory products have also met some pretty strenuous global standards requirements. Tests some V-Gard Accessories have passed include:

- Resistance to surface penetration by molten grey iron metal, heated to 2642°F/1450°C.
- Conditioning to temperature extremes between 23°F/-5°C and 131°F/55°C, then impact testing with a metal ball moving > 268 mph.
- Resistance to surface penetration by a steel ball super-heated to 1652°F/900°C.

**V-Gard Accessory System: Going beyond the standards to Make the World Safer, One Person at a Time.®**



## Table of Contents

---

Keys to Safety	2
The V-Gard® Helmet Gets a Face Lift!	3
V-Gard Frame for Slotted Caps: Key Features	4
V-Gard Universal Frame for Caps: Key Features	5
V-Gard Frames	6
Anatomy of a Packaging Label	7
V-Gard Visor Shapes and Sizes	7
Choosing the Proper V-Gard Visor	8
V-Gard Visors for General Purpose Applications	9-10
V-Gard Visors for Chemical and Splash Applications	11
V-Gard Visors for Elevated Temperature Applications	12
V-Gard Visors for Welding Applications	13
V-Gard Visors for Arc Flash Applications	13
V-Gard Chin Protectors	14
V-Gard Accessory System Kits	14
V-Gard Accessory System Replacement Parts	14
Chemical Application Quick Reference Guide	15

## The V-Gard Helmet Gets a Face Lift!

---

Renowned for quality, dependability and life-saving testimonials, the iconic V-Gard Helmet with its unique V-shaped design is the head protection choice of workers world-wide. No other hard hat possesses the trust people have in their V-Gard Helmets to keep them safe.

### **So how did MSA make the best hard hat even better? By listening to V-Gard owners.**

You wanted to select a visor, frame and chin protector and not worry about compatibility or compliance. You wanted a system that accommodates other personal protective equipment, like earmuffs and respirators. Most of all, you wanted reliable face protection helmet accessories that offer the same high standard of quality as the V-Gard Helmet you already trust.

### **And MSA delivered!**

Introducing the V-Gard Accessory System – frames, visors, and chin protectors designed for MSA V-Gard Helmets. Reliable accessories offering the same high standard of protection as the V-Gard Helmet. And for those who love other MSA helmets (such as the Skullgard® Helmet), a universal version of the V-Gard Frame fits any MSA slotted or non-slotted helmet.

### **Compliance made easy.**

Why choose MSA's new line of V-Gard accessories when competitors' visors and frames may *appear* to be compatible? Because *only* V-Gard Accessory System products are tested and approved as a system to work with MSA Safety Helmets.

### **Simple ordering.**

V-Gard Accessories meet applicable global standard requirements – with only one part number per product!

## V-Gard Frame for Slotted Caps: Key Features



V-Gard Frame for Slotted MSA Caps with debris control (PN 10115730). Shown with V-Gard clear molded, propionate visor (PN 10115855) and MSA left/RIGHT® (HIGH) earmuffs (PN 10087422) on a V-Gard Cap.

<sup>1</sup>Patent pending

## V-Gard Universal Frame for Caps: Key Features

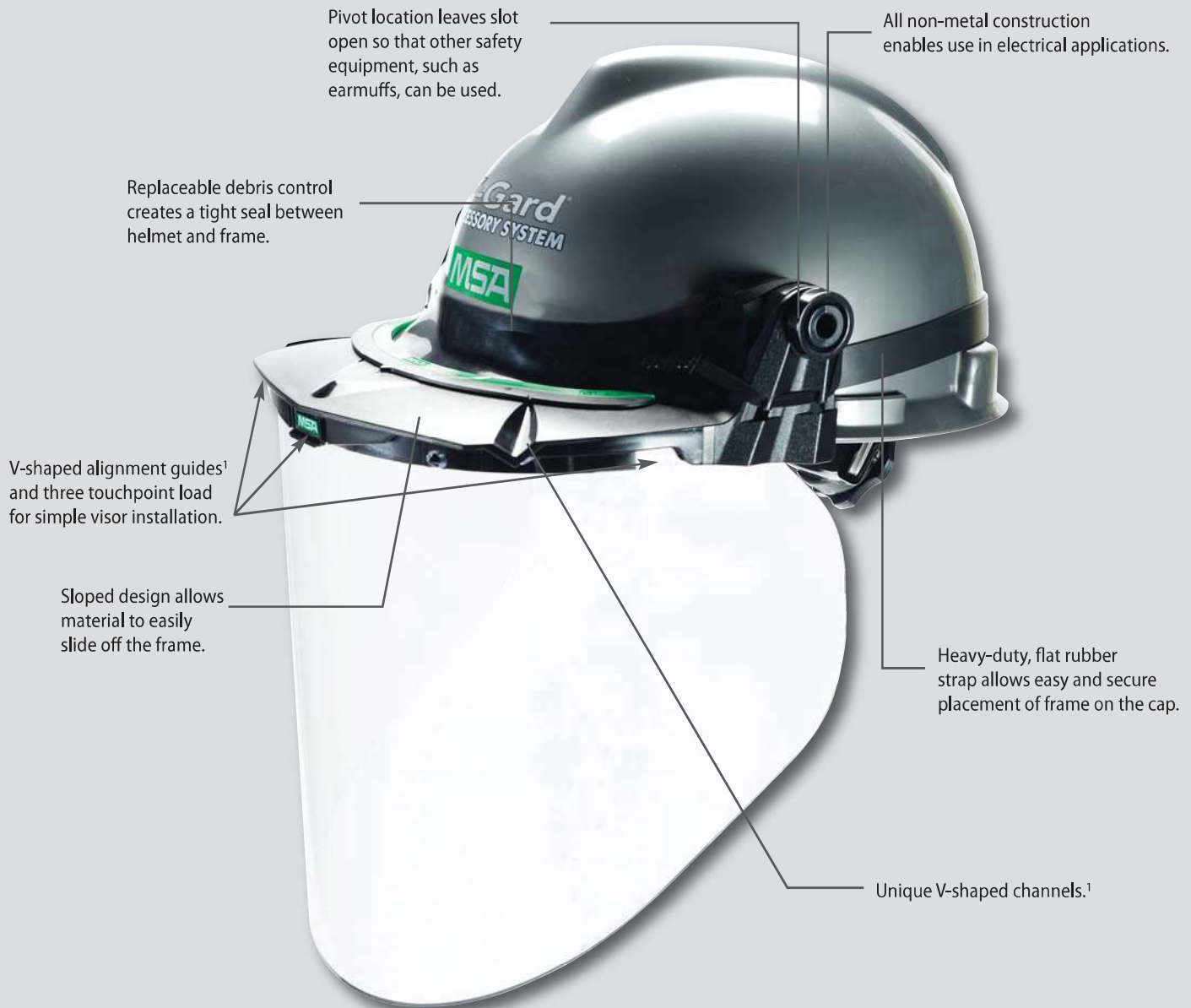

V-Gard Universal Frame for Non-Slotted or Slotted Caps with debris control (PN 10115822).  
Shown with V-Gard clear, molded polycarbonate visor (PN 10115853) on a V-Gard Cap.

<sup>1</sup>Patent pending

## V-Gard Frames





The V-Gard Accessory System offers helmet-mounted frames for various work conditions and MSA helmets.

The sloped design allows liquids, chips and other materials to slide off the frame and away from the line of sight. Each frame, whether used with or without debris control, meets the applicable requirements for ANSI/ISEA Z87.1-2010, EN 166, CSA Z94.3 and AS/NZS 1337, as well as many local standards.<sup>1</sup>





### WARNING

Use V-Gard Frames **ONLY** with V-Gard Visors, to ensure compliance with safety standards. Misuse can result in death, permanent impairment of sight or other serious injury.



#### V-Gard Frames for Slotted MSA Caps

	P/N 10115730 V-Gard FRAME FOR MSA SLOTTED CAPS, WITH DEBRIS CONTROL	<ul style="list-style-type: none"> <li>• Stowable slot adapters<sup>2</sup> allow frames to work with or without earmuffs.</li> <li>• Replaceable debris-control creates a tight seal between helmet and the frame.</li> <li>• Sliding adjustment blades allow visor to work with most half-mask respirators.</li> <li>• Unique V-shaped channels.<sup>2</sup></li> <li>• Fits all slotted MSA caps.<sup>3</sup></li> <li>• ET frame tested to temperatures of 350°F (176.7°C), reducing warping, cracking or crazing.</li> </ul>
	P/N 10121266 V-Gard FRAME FOR MSA SLOTTED CAPS, WITHOUT DEBRIS CONTROL <sup>3</sup>	
	P/N 10115821 V-Gard FRAME FOR MSA SLOTTED CAPS, ELEVATED TEMPERATURE (ET), WITH DEBRIS CONTROL	
	P/N 10121267 V-Gard FRAME FOR MSA SLOTTED CAPS, ET, WITHOUT DEBRIS CONTROL	

#### V-Gard Universal Frames for Slotted or Non-Slotted MSA Caps

	P/N 10115822 V-Gard UNIVERSAL FRAME FOR CAPS, WITH DEBRIS CONTROL	<ul style="list-style-type: none"> <li>• Heavy-duty, flat rubber strap allows easy and secure placement of frame on the cap.</li> <li>• Design allows use with other personal protective equipment, such as earmuffs and most half-mask respirators.</li> <li>• Non-metal construction enables use in electrical applications.</li> <li>• Unique V-shaped channels.<sup>2</sup></li> <li>• Fits all MSA caps.<sup>3,4</sup></li> <li>• Replaceable debris control creates a tight seal between the helmet and the frame.</li> <li>• ET frame designed to withstand temperatures of 350°F (176.1°C), reducing warping, cracking or crazing.</li> </ul>
	P/N 10121268 V-Gard UNIVERSAL FRAME FOR CAPS, WITHOUT DEBRIS CONTROL	
	P/N 10116552 V-Gard UNIVERSAL FRAME FOR CAPS, ET, WITH DEBRIS CONTROL	
	P/N 10124426 V-Gard UNIVERSAL FRAME FOR CAPS, ET, WITHOUT DEBRIS CONTROL	

#### V-Gard Frames for MSA Full-Brim Hats

	P/N 10116627 V-Gard FRAME FOR HATS	<ul style="list-style-type: none"> <li>• Design allows use with other personal protective equipment, such as earmuffs and most half-mask respirators.</li> <li>• Heavy-duty rubber strap prevents frame from slipping off of hats.</li> <li>• Fits all MSA full-brim hats.</li> <li>• Unique V-shaped channels.<sup>2</sup></li> <li>• ET frame designed to withstand temperatures of 350°F (176.7°C), reducing warping, cracking or crazing.</li> </ul>
	P/N 10116628 V-Gard FRAME FOR HATS, ET	

<sup>1</sup> Standards requirements met by V-Gard Frame/V-Gard Visor combinations are indicated on each V-Gard Visor.

<sup>2</sup> Patent pending.

<sup>3</sup> MSA recommends the use of debris control on V-Gard frames when wearing both cap-mounted earmuffs and V-Gard molded visors.

<sup>4</sup> MSA does not recommend the use of the V-Gard Universal Frame with the MSA Smooth Dome cap when using cap-mounted earmuffs and V-Gard Molded visors. The MSA V-Gard Frame for Slotted Caps can be used for this particular combination.

## Anatomy of a Packaging Label

All MSA V-Gard Accessories are packaged for ease of selection at point of purchase. With barcodes and helpful customer-approved product feature icons, MSA makes it simple for customers to select the proper product.

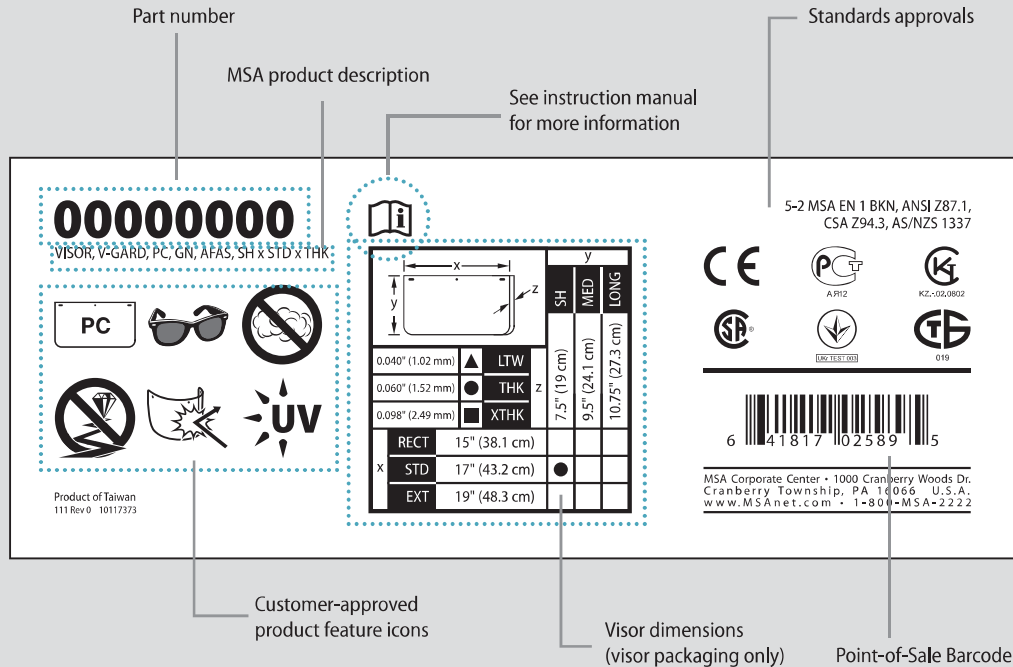

## V-Gard Visor Shapes and Sizes

The following V-Gard Visor shapes and sizes are included in the V-Gard Accessory System:

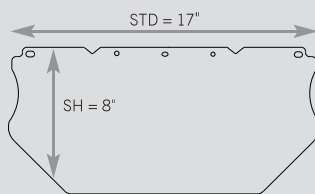

Available in .04" (LTW) and .06" (THK).  
Available as nitrometer.  
Available in flat and side-contoured versions.

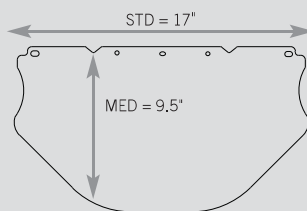

Available in .04" (LTW).  
Available in flat and side-contoured versions.

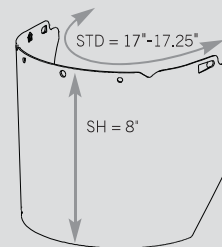

Available in .07" (THK) and .098" (XTHK).  
Available as nitrometer.

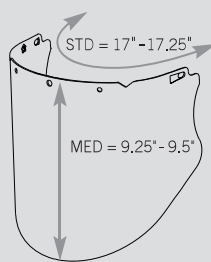

Available in .098" (XTHK).

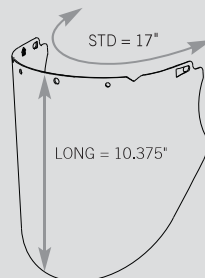

Available in .098" (XTHK).

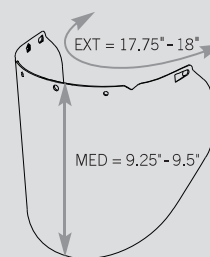





Available in .07" (THK) and .098" (XTHK).

## Choosing the Proper V-Gard Visor

The V-Gard Accessory System includes a full line of V-Gard Visors for a variety of applications: from general purpose to elevated temperature. Many V-Gard Visors are designed for use with V-Gard Chin Protectors (look for visors noted as "Nitrometers"). And since all V-Gard Visors fit all V-Gard Frames, it's easy to select a combination that is compliant and meets just about any safety need.

When choosing a V-Gard Visor, first assess possible environmental hazards. Is there excessive glare, humidity or exposure to infrared (IR) radiation? Is there a risk of impact, chemical splash or arc flash hazards? The chart below lists the benefits of different V-Gard Visors.

<b>MATERIAL</b>	Polycarbonate	Suitable for most applications where impact hazards exist. Available in a variety of sizes and thicknesses. Provides Ultraviolet (UV) protection, where noted. Molded polycarbonate visors also provide protection against some chemical splash. <i>See Chemical Application Quick Reference Guide.</i>
	Mesh	Provides maximum ventilation in humid working conditions. Lightweight and durable – great for outdoor applications such as brush clearing and trimming. <b>Does not provide impact, splash or UV protection.</b>
	Propionate	V-Gard propionate visors provide impact resistance. Good for many applications where chemical splash hazards exist. <i>See Chemical Application Quick Reference Guide.</i>
<b>COLOR/TINT</b>	Clear 	Provides maximum light transmission. Good for indoor applications, or outdoor use in low-light conditions.
	Green Tint 	Helps alleviate eye strain and fatigue by reducing excessive glare and light transmittance. All green tint V-Gard Visors offer maximum UV protection. <b>Not for use where an IR shade visor is required.</b>
	Shade 3 IR / Shade 5 IR 	Helps protect against IR up to Shade 3 or Shade 5, as applicable. Perfect for welding, metal pouring, gas soldering, light cutting, and brazing applications.
	Arc 	Helps protect against low-level arc flash hazards. This special purpose tinted lens offers protection from electromagnetic energy, fragments and molten metals that could be released during an electric arc.
<b>COATINGS</b>	Anti-fog	Controls condensation build-up on inside of visor surface. Great for humid conditions. V-Gard Molded Visors offering anti-fog are marked with an EN "N" marking, having passed strenuous testing to confirm anti-fogging properties.
	Anti-scratch	Provides excellent scratch resistance, extending visor life. A "must have" in abrasive work environments. V-Gard Molded Visors offering anti-scratch are marked with an EN "K" marking, having passed strenuous testing to confirm anti-scratch properties.
	Reflective	Helps protect against long-term IR exposure generated in elevated temperature environments (EN 166 "R" mark). Coating also helps dissipate heat felt by wearer. Available in clear and green tint. Offers maximum UV protection.





### **WARNING**

**Wear MSA impact-rated spectacles or goggles under visors. Inspect visors frequently and replace immediately if worn, scratched or damaged.**





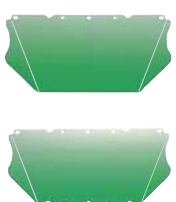

**Use V-Gard Visors ONLY with V-Gard Frames and V-Gard Chin Protectors to ensure compliance with ANSI/ISEA Z87.1-2010, EN 166, CSA Z94.3, and AS/NZS 1337, as well as many local standards. Misuse can result in death, permanent impairment of sight or other serious injury.**

## V-Gard Visors for General Purpose Applications

These visors are made of durable polycarbonate or mesh, and help protect wearers from flying debris, splash or spray<sup>1</sup>. All V-Gard Visors for general purpose can be worn with cap-mounted earmuffs.

	<p>P/N 10115836 CLEAR, PC, SIDE CONTOURS</p> <p>P/N 10115837 CLEAR, PC, NITROMETER, SIDE CONTOURS</p> <p>P/N 10120108 CLEAR, PC, SIDE CONTOURS, BULK PACK OF 20</p>	<ul style="list-style-type: none"> <li>• 8" (20.3 cm) x 17" (43.2 cm) x .04" (1.02 mm).</li> <li>• Sides of visor are contoured towards face for a closer fit and improved resistance to impact and splash hazards.</li> <li>• Maximum UV protection.</li> <li>• Nitrometer can <b>only</b> be used with V-Gard Retractable or Standard Chin Protector.</li> <li>• Meets requirements for EN 166 (2C-1.2 MSA 1B), ANSI/ISEA Z87.1-2010, CSA Z94.3 and AS/NZS 1337.</li> </ul>
	<p>P/N 10115863 CLEAR, PC, SIDE CONTOURS</p>	<ul style="list-style-type: none"> <li>• 9.5" (24.1 cm) x 17" (43.2 cm) x .04" (1.02 mm).</li> <li>• Sides of visor are contoured towards face for a closer fit, and improved resistance to impact and splash hazards.</li> <li>• Slightly longer and wider design offers extended coverage.</li> <li>• Maximum UV protection.</li> <li>• Meets requirements for EN 166 (2C-1.2 MSA 1B), ANSI/ISEA Z87.1-2010, CSA Z94.3 and AS/NZS 1337.</li> </ul>
	<p>P/N 10115839 CLEAR, PC, SIDE CONTOURS, AF/AS</p> <p>P/N 10115841 CLEAR, PC, SIDE CONTOURS, NITROMETER, AF/AS</p>	<ul style="list-style-type: none"> <li>• 8" (20.32 cm) x 17" (43.2 cm) x .06" (1.52 mm).</li> <li>• Anti-fog and anti-scratch coatings.</li> <li>• Sides of visor are contoured towards face for a closer fit and improved resistance to impact and splash hazards.</li> <li>• Maximum UV protection.</li> <li>• Slightly thicker for industrial impact applications such as cutting metal.</li> <li>• Nitrometer can <b>only</b> be used with V-Gard Retractable or Standard Chin Protector.</li> <li>• Meets requirements for ANSI/ISEA Z87.1-2010 and CSA Z94.3.</li> </ul>
	<p>P/N 10115840 CLEAR, PC, SIDE CONTOURS, NO AF/AS</p>	<ul style="list-style-type: none"> <li>• 8" (20.32 cm) x 17" (43.2 cm) x .06" (1.52 mm).</li> <li>• Sides of visor are contoured towards face for a closer fit and improved resistance to impact and splash hazards.</li> <li>• Slightly thicker for industrial applications such as cutting metal.</li> <li>• Maximum UV protection.</li> <li>• Meets requirements for EN 166 (2C-1.2 MSA 1B89), ANSI/ISEA Z87.1-2010, CSA Z94.3 and AS/NZS 1337.</li> </ul>
	<p>P/N 10115842 GREEN TINT, PC, SIDE CONTOURS, AF/AS</p> <p>P/N 10115843 GREEN TINT, PC, SIDE CONTOURS, NITROMETER, AF/AS</p>	<ul style="list-style-type: none"> <li>• 8" (20.32 cm) x 17" (43.2 cm) x .06" (1.52 mm).</li> <li>• Anti-fog and anti-scratch coatings.</li> <li>• Sides of visor are contoured towards face for a closer fit and improved resistance to impact and splash hazards.</li> <li>• Maximum UV protection.</li> <li>• Slightly thicker for industrial impact applications, such as grinding.</li> <li>• Green tint helps alleviate eye strain and fatigue by reducing excessive glare, especially in outdoor working conditions. <b>Not for use where a Shade Infrared (IR) visor is required.</b></li> <li>• Nitrometer can <b>only</b> be used with V-Gard Retractable or Standard Chin Protector.</li> <li>• Meets requirements for ANSI/ISEA Z87.1-2010 and CSA Z94.3.</li> </ul>





<sup>1</sup> Exceptions are noted in the General Purpose Visor product descriptions.

	<p>P/N 10117750 CLEAR, PC FLAT, (NON-CSA VERSION)</p> <p>P/N 10117781 CLEAR, PC FLAT, NITROMETER (NON-CSA VERSION)</p>	<ul style="list-style-type: none"> <li>• 8" (20.3 cm) x 17" (43.2 cm) x .04" (1.02 mm).</li> <li>• Wider design for improved resistance to impact and splash hazards.</li> <li>• Maximum UV protection.</li> <li>• Nitrometer can only be used with V-Gard Retractable or Standard Chin Protector.</li> <li>• Meets requirements for EN 166 (2C-1.2 MSA 1B89), ANSI/ISEA Z87.1-2010, and AS/NZS 1337.</li> </ul>
	<p>P/N 10118094 CLEAR, PC FLAT (NON-CSA VERSION)</p>	<ul style="list-style-type: none"> <li>• 9.5" (24.1 cm) x 17" (43.2 cm) x .04" (1.02 mm).</li> <li>• Slightly longer and wider design offers extended coverage for improved resistance to impact and splash hazards.</li> <li>• Maximum UV protection.</li> <li>• Meets requirements for EN 166 (2C-1.2 MSA 1B89), ANSI/ISEA Z87.1-2010, and AS/NZS 1337.</li> </ul>
	<p>P/N 10117782 CLEAR, PC FLAT (NON-CSA VERSION)</p> <p>P/N 10117783 CLEAR, PC FLAT, NITROMETER (NON-CSA VERSION)</p>	<ul style="list-style-type: none"> <li>• 8" (20.32 cm) x 17" (43.2 cm) x .06" (1.52 mm).</li> <li>• Wider design for improved resistance to impact and splash hazards.</li> <li>• Slightly thicker for industrial applications such as cutting metal.</li> <li>• Maximum UV protection.</li> <li>• Nitrometer can only be used with V-Gard Retractable or Standard Chin Protector.</li> <li>• Meets requirements for EN 166 (2C-1.2 MSA 1B89), ANSI/ISEA Z87.1-2010, and AS/NZS 1337.</li> </ul>
	<p>P/N 10115853 CLEAR, PC MOLDED, AF/AS</p>	<ul style="list-style-type: none"> <li>• 10.375" (26.4 cm) x 17" (43.2 cm) x .098" (2.5 mm).</li> <li>• Designed for heavy duty use – thicker than most visors on the market. Performs well against many chemicals.<sup>1</sup></li> <li>• Maximum UV protection.</li> <li>• Molded for superior optical quality.</li> <li>• Extended length for greater coverage of face and neck.</li> <li>• EN-rated anti-fog and anti-scratch coatings.</li> <li>• Meets requirements for EN 166 (2C-1.2 MSA1BT89KN), ANSI/ISEA Z87.1-2010, CSA Z94.3, and AS/NZS 1337.</li> </ul>
	<p>P/N 10115854 GREEN TINT, PC MOLDED, AF/AS</p>	<ul style="list-style-type: none"> <li>• 10.375" (26.4 cm) x 17" (43.2 cm) x .098" (2.5 mm).</li> <li>• Designed for heavy duty use – thicker than most visors on the market. Performs well against many chemicals.<sup>1</sup></li> <li>• Maximum UV protection.</li> <li>• Molded for superior optical quality.</li> <li>• Extended length for greater coverage of face and neck.</li> <li>• Green tint helps alleviate eye strain and fatigue by reducing excessive glare, especially in outdoor working conditions. <b>Not for use where a Shade Infrared (IR) visor is required.</b></li> <li>• EN-rated anti-fog and anti-scratch coatings.</li> <li>• Meets requirements for EN 166 (2-2 MSA1BT9KN), ANSI/ISEA Z87.1-2010, CSA Z94.3, and AS/NZS 1337.</li> </ul>
	<p>P/N 10116557 MESH WITH PLASTIC EDGE</p> <p>P/N 10116558 MESH WITH PLASTIC EDGE, NITROMETER</p>	<ul style="list-style-type: none"> <li>• 8" (20.3 cm) x 17" (43.2 cm).</li> <li>• Durable, epoxy-coated 20 x 20 steel mesh, bound with heavy-duty plastic.</li> <li>• Nitrometer can only be used with V-Gard Retractable or Standard Chin Protector.</li> <li>• Meets requirements for EN 1731-F, ANSI/ISEA Z87.1-2010 (general protector) and AS/NZS 1337.</li> <li>• <b>Do not use where splash, elevated temperatures, UV or impact hazards exist.</b></li> </ul>
	<p>P/N 10116556 ALUMINUM BOUND MESH</p>	<ul style="list-style-type: none"> <li>• 8" (20.3 cm) x 16.5" (41.9 cm).</li> <li>• Durable, epoxy-coated 20 x 20 steel mesh, bound with heavy-duty aluminum.</li> <li>• Meets requirements for EN 1731-F, ANSI/ISEA Z87.1-2010 (general protector) and AS/NZS 1337.</li> <li>• <b>Do not use where splash, UV, electrical or impact hazards exist.</b></li> </ul>

<sup>1</sup> Refer to the our Chemical Application Quick Reference Guide (found in this brochure) for performance against select chemical families.

## V-Gard Visors for Chemical and Splash Applications

These propionate visors are for chemical and splash applications, and are ideal for use in manufacturing plants, laboratories and other industrial applications that demand face protection against impact hazards, abrasive particles, splash and spray.<sup>1</sup> Molded V-Gard Visors are manufactured with hand-polished molds for unsurpassed, distortion-free optical clarity.







	<p>P/N 10115855 CLEAR PROPIONATE, MOLDED</p> <p>P/N 10115856 CLEAR PROPIONATE, MOLDED, NITROMETER</p>	<ul style="list-style-type: none"> <li>• 8" (20.3 cm) x 17" (43.2 cm) x .098" (2.5 mm).</li> <li>• Impact-rated protection.</li> <li>• Molded for superior optical quality.</li> <li>• Extra thick to help prevent warping, cracking or crazing under tough work conditions.</li> <li>• Nitrometer can only be used with V-Gard Retractable or Standard Chin Protector.</li> <li>• Meets requirements for EN 166 (MSA 1 B 3), ANSI/ISEA Z87.1-2010, CSA Z94.3 and AS/NZS 1337.</li> </ul>
	<p>P/N 10115851 CLEAR PROPIONATE, MOLDED</p>	<ul style="list-style-type: none"> <li>• 9.25" (23.5 cm) x 18" (45.7 cm) x .098" (2.5 mm).</li> <li>• Impact-rated protection.</li> <li>• Molded for superior optical quality.</li> <li>• Extended length and width for greater coverage of face and neck.<sup>2</sup></li> <li>• Extra thick to help prevent warping, cracking or crazing under tough work conditions.</li> <li>• Meets requirements for EN 166 (MSA 1 B 3), ANSI/ISEA Z87.1-2010, CSA Z94.3 and AS/NZS 1337.</li> </ul>
	<p>P/N 10115857 GREEN TINT, PROPIONATE, MOLDED</p>	<ul style="list-style-type: none"> <li>• 8" (20.3 cm) x 17" (43.2 cm) x .098" (2.5 mm).</li> <li>• Impact-rated protection.</li> <li>• Molded for superior optical quality.</li> <li>• Green tint offers maximum UV protection, and helps alleviate eye strain and fatigue by reducing excessive glare. <b>Not for use where an IR Shade visor is required.</b></li> <li>• Great for outdoor work where impact risks, exposure to select chemicals and other splash hazards exist.</li> <li>• Meets requirements for ANSI/ISEA Z87.1-2010 and CSA Z94.3.</li> </ul>
	<p>P/N 10115852 GREEN TINT, PROPIONATE, MOLDED</p>	<ul style="list-style-type: none"> <li>• 9.25" (23.5 cm) x 18" (45.7 cm) x .098" (2.5 mm).</li> <li>• Impact-rated protection.</li> <li>• Molded for superior optical quality.</li> <li>• Green tint offers maximum UV protection and helps alleviate eye strain and fatigue by reducing excessive glare. <b>Not for use where an IR Shade visor is required.</b></li> <li>• Great for outdoor work where impact risks, exposure to select chemicals and other splash hazards exist.</li> <li>• Extended length and width for greater coverage of face and neck.<sup>2</sup></li> <li>• Meets requirements for ANSI/ISEA Z87.1-2010 and CSA Z94.3.</li> </ul>

<sup>1</sup> Refer to our Chemical Application Quick Reference Guide (found in this brochure) for performance against select chemical families.

<sup>2</sup> Visor may not close fully when worn with earmuffs.

## V-Gard Visors for Elevated Temperature Applications

These PC visors help keep workers comfortable in environments such as steel/smelting plants where they are exposed to high levels of heat and/or excessive glare.<sup>1</sup> Our V-Gard Visors are engineered for heavy duty use and are thicker than most visors in the marketplace, which not only helps ensure impact resistance, but also reduces heat warping.



	<p>P/N 10115844 CLEAR PC, MOLDED, AF/AS</p>	<ul style="list-style-type: none"> <li>• 9.25" (23.5 cm) x 17" (43.2 cm) x .098" (2.5 mm).</li> <li>• Extended length for greater coverage of face and neck.</li> <li>• Extra thick to help prevent warping, cracking or crazing under tough work conditions.</li> <li>• Maximum UV protection.</li> <li>• Molded for superior optical quality.</li> <li>• EN-rated anti-fog and anti-scratch coatings.</li> <li>• Meets requirements for EN 166 (2C-1.2 MSA1BT89KN), ANSI/ISEA Z87.1-2010, CSA Z94.3 and AS/NZS 1337.</li> </ul>
	<p>P/N 10115845 GREEN TINT PC, MOLDED, AF/AS</p>	<ul style="list-style-type: none"> <li>• 9.25" (23.5 cm) x 17" (43.2 cm) x .098" (2.5 mm).</li> <li>• Extended length for greater coverage of face and neck.</li> <li>• Extra thick to help prevent warping, cracking or crazing under tough work conditions.</li> <li>• Maximum UV protection.</li> <li>• Molded for superior optical quality.</li> <li>• EN-rated anti-fog and anti-scratch coatings.</li> <li>• Green tint helps alleviate eye strain and fatigue by reducing excessive glare. <b>Not for use where an IR Shade visor is required.</b></li> <li>• Meets requirements for EN 166 (2.2 MSA1BT9KN), ANSI/ISEA Z87.1-2010, CSA Z94.3 and AS/NZS 1337.</li> </ul>
	<p>P/N 10115846 CLEAR PC, MOLDED, AF/AS</p>	<ul style="list-style-type: none"> <li>• 9.25" (23.5 cm) x 18" (45.7 cm) x .098" (2.5 mm).</li> <li>• Extended length and width for greater coverage of face and neck.<sup>2</sup></li> <li>• Extra thick to help prevent warping, cracking or crazing under tough work conditions.</li> <li>• Maximum UV protection.</li> <li>• Molded for superior optical quality.</li> <li>• EN-rated anti-fog and anti-scratch coatings.</li> <li>• Meets requirements for EN 166 (2.2 MSA1BT9KN), ANSI/ISEA Z87.1-2010, CSA Z94.3 and AS/NZS 1337.</li> </ul>
	<p>P/N 10115849 GREEN TINT PC, MOLDED, AF/AS</p>	<ul style="list-style-type: none"> <li>• 9.25" (23.5 cm) x 18" (45.7 cm) x .098" (2.5 mm).</li> <li>• Extended length and width for greater coverage of face and neck.<sup>2</sup></li> <li>• Extra thick to help prevent warping, cracking or crazing under tough work conditions.</li> <li>• Maximum UV protection.</li> <li>• Molded for superior optical quality.</li> <li>• Green tint helps alleviate eye strain and fatigue by reducing excessive glare. <b>Not for use where a specific IR Shade visor would perform better and/or is required.</b></li> <li>• EN-rated anti-fog and anti-scratch coatings.</li> <li>• Meets requirements for EN 166 (2.2 MSA1BT9KN), ANSI/ISEA Z87.1-2010, CSA Z94.3 and AS/NZS 1337.</li> </ul>
	<p>P/N 10115848 CLEAR PC, REFLECTIVE COATING, MOLDED</p>	<ul style="list-style-type: none"> <li>• 9.5" (24.1 cm) x 17.75" (45.09 cm) x .07" (1.78 mm).</li> <li>• Reflective coating helps filter IR radiation and dissipate heat.</li> <li>• Maximum UV protection.</li> <li>• Extended length and width for greater coverage of face and neck.<sup>2</sup></li> <li>• Meets requirements for EN 166 (2C-2.5 MSA 1BT3R), ANSI/ISEA Z87.1-2010, CSA Z94.3 and AS/NZS 1337.</li> </ul>
	<p>P/N 10115850 GREEN TINT PC, REFLECTIVE COATING, MOLDED</p>	<ul style="list-style-type: none"> <li>• 9.5" (24.1 cm) x 17.75" (45.09 cm) x .07" (1.78 mm).</li> <li>• Reflective coating helps filter IR and dissipate heat.</li> <li>• Maximum UV protection.</li> <li>• Green tint helps alleviate eye strain and fatigue by reducing excessive glare. <b>Not for use where an IR Shade visor is required.</b></li> <li>• Extended length and width for greater coverage of face and neck.<sup>2</sup></li> <li>• Meets requirements for EN 166 (2-4 MSA 1BT3R), ANSI/ISEA Z87.1-2010, CSA Z94.3 and AS/NZS 1337.</li> </ul>

<sup>1</sup> The proper personal protective equipment should be selected for use and application by the site safety specialist, whose responsibility is to ensure hazards, communication of instructions, precautions and limitations are conveyed and observed.

<sup>2</sup> Visor may not close fully when worn with earmuffs.

## V-Gard Visors for Welding Applications



These PC visors help protect against damage from impact and infrared (IR) radiation. Designed for welding, metal pouring, gas soldering, and light cutting/brazing, they're engineered for heavy-duty use. They are thick to help prevent warping from heat or weld spatter.

	<p>P/N 10115859 SHADE 3 IR, PC, MOLDED</p> <p>P/N 10115860 SHADE 3 IR, PC, MOLDED NITROMETER</p>	<ul style="list-style-type: none"> <li>• 8" (20.3 cm) x 17.25" (43.8 cm) x .07" (1.8 mm).</li> <li>• Designed for impact resistance and protection from IR up to Shade 3.</li> <li>• Nitrometer can <b>only</b> be used with V-Gard Retractable or Standard Chin Protector.</li> <li>• Meets requirements for EN166 (4-3/3MSA1BT 9), ANSI/ISEA Z87.1-2010 (for welding) and is certified to CSA Z94.3 (for shade).</li> </ul>
	<p>P/N 10115861 SHADE 5 IR, PC, MOLDED</p> <p>P/N 10115862 SHADE 5 IR, PC, MOLDED NITROMETER</p>	<ul style="list-style-type: none"> <li>• 8" (20.3 cm) x 17.25" (43.8 cm) x .07" (1.8 mm).</li> <li>• Designed for impact resistance and protection from IR up to Shade 5.</li> <li>• Nitrometer can <b>only</b> be used with V-Gard Retractable or Standard Chin Protector.</li> <li>• Meets requirements for EN166 (4-5/5MSA1BT 9), ANSI/ISEA Z87.1-2010 (for welding) and is certified to CSA Z94.3 (for shade).</li> </ul>

## V-Gard Visors for Arc Flash Applications

These PC visors are engineered to help protect against impact and dangerous arc flash hazards. Perfect for electrical workers and electricians working with high-voltage connections.



**Note:** V-Gard Arc Visors are intended to be used only with dielectric frames and helmets.

	<p>P/N 10115847 ARC, PC, MOLDED</p>	<ul style="list-style-type: none"> <li>• 9.25" (23.5 cm) x 18" (45.7 cm) x .065" (1.7 mm).</li> <li>• Impact-rated protection.</li> <li>• Extended length and width for greater coverage of face and neck.</li> <li>• Meets requirements for ANSI/ISEA Z87.1-2010.</li> <li>• <b>Rated to 12.9 cal/cm<sup>2</sup> when tested to ASTM F2178-2008 (ref. NFPA 70E-2012, Hazard Risk Category 2), and when worn with a V-Gard Hard Hat (PN 475358) and V-Gard Frame (PN 10121266).</b></li> <li>• Call MSA Customer Service (800-MSA-2222) for protection levels when using this V-Gard Arc Visor with other V-Gard Frames and MSA Helmet combinations.</li> </ul>
	<p>P/N 10118480 ARC, PC, MOLDED, NITROMETER, WITH V-GARD STANDARD CHIN PROTECTOR</p>	<ul style="list-style-type: none"> <li>• 8" (20.3 cm) x 17.25" (43.8 cm) x .065" (1.7 mm) + 3.02" (7.7 cm) (chin protector length).</li> <li>• Impact-rated protection.</li> <li>• Includes V-Gard Standard Chin Protector (required to achieve arc rating); must be assembled onto visor by user.</li> <li>• Meets requirements for ANSI/ISEA Z87.1-2010.</li> <li>• <b>Rated to 11.3 cal/cm<sup>2</sup> when tested to ASTM F2178-2008 (ref. NFPA 70E-2012, Hazard Risk Category 2) and when worn with a V-Gard Hard Hat (PN 475358), V-Gard Frame (PN 10121266), and V-Gard Standard Chin Protector (PN/10115827).</b></li> <li>• Call MSA Customer Service (800-MSA-2222) for protection levels when using this V-Gard Arc Visor with other V-Gard Frames, V-Gard Chin Protectors and MSA Helmet combinations.</li> </ul>

## V-Gard Chin Protectors





V-Gard Chin Protectors work with select V-Gard Nitrometers to help provide extra protection from impact and splash hazards to face and neck.

**Note:** MSA V-Gard Chin Protectors meet the applicable safety requirements as noted on the V-Gard Nitrometer Visor when worn in conjunction with V-Gard Frames and V-Gard Nitrometer Visors.



	<p>P/N 10115828 RETRACTABLE CHIN PROTECTOR</p>	<ul style="list-style-type: none"> <li>• 3.82" (9.7 cm) in height, when unretracted.</li> <li>• Unique retractable plates allow greater flexibility of head movement both up and down, as well as side to side.</li> <li>• Opaque material ensures safety and standards compliance with clear, tinted, shaded and coated V-Gard Visors.</li> </ul>
	<p>P/N 10115827 STANDARD CHIN PROTECTOR</p>	<ul style="list-style-type: none"> <li>• 2.86" (7.26 cm) in height.</li> <li>• Opaque material ensures safety and standards compliance with clear, tinted, shaded and coated V-Gard Visors.</li> <li>• Compact, lightweight design provides additional protection between chin and neck area.</li> </ul>

## V-Gard Accessory System Kits

V-Gard Accessory System Kits are designed to offer easy customer solutions for a variety of needs – all in one convenient box.

	<p>P/N 10118695 V-Gard ACCESSORY SYSTEM KIT WITH V-GARD CAP</p>	<p><b>Contains:</b></p> <ul style="list-style-type: none"> <li>• White V-Gard Cap with ratchet suspension (PN 475358).</li> <li>• V-Gard Frame for Slotted Caps, with debris control (PN 10115730).</li> <li>• V-Gard Clear, PC Visor, 8" (20.3 cm) x 17" (43.2 cm) x .04" (1.02 mm) (PN 10115836).</li> </ul>
	<p>P/N 10118697 V-Gard ACCESSORY SYSTEM KIT (WITHOUT V-GARD CAP)</p>	<p><b>Contains:</b></p> <ul style="list-style-type: none"> <li>• V-Gard Universal Frame for Caps, with debris control (PN 10115822).</li> <li>• V-Gard Clear, PC Visor, 8" (20.3 cm) x 17" (43.2 cm) x .04" (1.02 mm) (PN 10115836).</li> </ul> <p><b>Does not contain an MSA safety helmet.</b></p>
	<p>P/N 10118694 V-Gard FORESTRY KIT</p>	<p><b>Contains:</b></p> <ul style="list-style-type: none"> <li>• Hi-viz orange V-Gard Cap with ratchet suspension (PN 488146).</li> <li>• V-Gard Frame for Slotted Caps, with debris control (PN 10115730).</li> <li>• V-Gard Mesh Nitrometer (PN 10116558).</li> <li>• V-Gard Retractable Chin Protector (PN 10115828).</li> <li>• Left/RIGHT, HIGH (NRR 28 db) Cap-Mounted Earmuffs (PN 10087422).</li> </ul>
	<p>P/N 10118696 V-Gard ACCESSORY ARC KIT</p>	<p><b>Contains:</b></p> <ul style="list-style-type: none"> <li>• White V-Gard Cap with ratchet suspension (PN 475358).</li> <li>• V-Gard Frame for Slotted Caps, (PN 10121266).</li> <li>• V-Gard Arc Nitrometer with V-Gard Standard Chin Protector (PN 10118480); must be assembled by user and worn together to achieve calorie rating.</li> <li>• <b>Rated to 11.3 cal/cm<sup>2</sup> when tested to ASTM F2178-2008 (ref. NFPA 70E-2012, Hazard Risk Category 2), and when worn with a V-Gard Hard Hat (PN 475358)<sup>2</sup>, V-Gard Frame (PN 10121266) and V-Gard Standard Chin Protector (PN/10115827), as shown.</b></li> </ul>

## V-Gard Accessory System Replacement Parts<sup>1</sup>

	<p>P/N 10117496 (2 PAIR)</p>	<ul style="list-style-type: none"> <li>• Slot adaptors (2 pair). For use with V-Gard Frames for Slotted Caps.</li> </ul>
	<p>P/N 10116539</p>	<ul style="list-style-type: none"> <li>• Debris control for V-Gard Cap Frames. Debris control exceeds EN requirements for molten metal.</li> </ul>
	<p>P/N 10117495</p>	<ul style="list-style-type: none"> <li>• Heavy duty rubber strap for V-Gard Universal Cap or Hat Frames.</li> </ul>

<sup>1</sup> Use only genuine MSA V-Gard Accessory System replacement parts to help ensure compatibility and compliance. MSA does not warrant, guarantee or promote the use of components manufactured by other companies when used in conjunction with MSA products.

<sup>2</sup> Call MSA Customer Service (800-MSA-2222) for protection levels when using this V-Gard Arc Visor with other V-Gard Frames, V-Gard Chin Protectors and MSA Helmet combinations.

## Chemical Application Quick Reference Guide

Chemical Family	Representative Chemical	Polycarbonate clear flat sheet (.04" - .06" thick), uncoated	Polycarbonate clear flat sheet (.06" thick), coated	Polycarbonate molded, clear (.098" thick), coated	Propionate clear molded (0.098" thick), uncoated
Organic Chemicals					
Alcohol	Ethanol	***	***	***	***
Aldehyde	Butyraldehyde	NR	NR	*	*
Aliphatic Hydrocarbon	Gasoline	* <sup>1</sup>	NR	***	*
Aromatic Hydrocarbon	Toluene	NR	NR	*	*
Ester	Butyl acetate	NR	NR	*	*
Ether	Ethyl ether	*	*	*	*
Ketone	Methyl isobutyl ketone (MIBK)	NR	NR	NR	*
Inorganic Chemicals					
Inorganic acid	Hydrochloric acid (35% wt)	***	NR	***	***
Inorganic base	Ammonium hydroxide (28% wt)	***	***	***	***
	Sodium hydroxide (25% wt)	***	NR	***	***
Other					
Bug spray	DEET	NR	NR	*	*

**NR (not recommended):** Crack(s) and/or severe warp and/or severe haze (i.e., that which renders the visor unusable) can be observed on visor after chemical spray; or the visor fails impact testing @ 120 m/s after spray. Visor should be inspected and replaced if damaged in any way.

**One-star (\*)** – No cracking observed on visor by un-aided eye after chemical spray. Visible haze may have been observed, but an assessment of the extent of visor usability as a result is subjective. In all cases, visor should be inspected and replaced if damaged in any way that renders it unusable in a particular environment. The visor passes impact testing @ 120 m/s after spray.

**Two-star (\*\*)** – No cracking observed on visor under microscope after chemical spray. Slight haze may have been observed, but an assessment of the extent of visor usability as a result is subjective. In all cases, visor should be inspected and replaced if damaged in any way that renders it unusable in a particular environment. The visor passes impact testing @ 120 m/s after spray.

**Three-star (\*\*\*)** – No cracking observed on visor under microscope after chemical spray. Only negligible haze may have been observed. Visor should be inspected and replaced if damaged in any way that renders it unusable in a particular environment. The visor passes impact testing @ 120 m/s after spray.

The results shown in the table were obtained under lab conditions (73.4 ± 3.6°F [23 ± 2°C] and 25 ± 5% relative humidity) in the MSA test labs. For testing purposes, V-Gard Visors were secured to V-Gard Frames in the "as worn" position. The results shown in this "Quick Reference Guide" are intended as a guide only to help in the selection of the proper V-Gard face protection products.

While the table shows the performance against certain chemicals, it is not intended to be all-inclusive and such testing is not required by safety standards. Additionally, the performance of any product can vary based on conditions of use (such as subsection of the material to different types of heat, the assessment of usability by the wearer, etc.). For these reasons, MSA recommends:

- The proper personal protective equipment should be selected for use and application by the site safety specialist, whose responsibility is that hazards, communication of instructions, precautions and limitations are conveyed and observed.
- Eye protection, such as MSA safety spectacles or goggles, as required for the application which meets the appropriate impact requirements, should be worn under any visor.
- Inspect visors frequently, and replace them immediately if worn, scratched, or damaged in any way.
- Use only V-Gard Frames with V-Gard Visors, and vice-versa. Incompatible products may not function as intended.

**For additional questions about V-Gard Visors and chemical resistance, please contact MSA Customer Service at 1-800-MSA-2222.**

<sup>1</sup> Not recommended (NR) against this chemical when using a PC, clear flat, uncoated, .06" visor.

For more information visit [www.MSAafety.com](http://www.MSAafety.com) Keyword: VGardSystem  
or call Customer Service 1.800.MSA.2222



**Note:** This bulletin contains only a general description of the products shown. While uses and performance capabilities are described, under no circumstances shall the products be used by untrained or unqualified individuals and not until the product instructions including any warnings or cautions provided have been thoroughly read and understood. Only they contain the complete and detailed information concerning proper use and care of these products.



**ID 0670-000-MC / Oct 2012**

© MSA 2012 Printed in U.S.A.

**Corporate Center**  
1000 Cranberry Woods Drive,  
Cranberry Township, PA 16066 USA  
Phone 724-776-8600  
[www.MSAafety.com](http://www.MSAafety.com)

**U.S. Customer Service Center**  
Phone 1-800-MSA-2222  
Fax 1-800-967-0398

**MSA Canada**  
Phone 1-800-672-2222  
Fax 1-800-967-0398

**MSA Mexico**  
Phone 01 800 672 7222  
Fax 52-44 2227 3943

**MSA International**  
Phone 724-776-8626  
Toll Free: 1-800-672-7777  
FAX 724-741-1559

